

Preface

Models covered by this manual

This manual covers the DestructData line of (Rackmount Erasure Devices) RED products with the RED240 being used as the primary example. Since all DestructData products are made to order there may be some differences between the diagrams and specifications contained in this manual and your RED configuration. This manual is restricted to the description of the basic RED machine and does not include specific information concerning additional backplane controllers. Please see the included documentation provided for any accessory.

Limited Warranty

DestructData warrants to the original purchaser that its external enclosure products, including the components therein, shall be free from defects in material and craftsmanship for a limited period of three (3) years from the date of invoice. These are the only warranties DestructData offers. DestructData makes no other warranties of any kind, express or implied, written, oral or statutory, and expressly disclaims any implied warranties, including merchantability or fitness for any specific purpose, or freedom from patent infringement, regardless of origin, under no circumstance is DestructData liable for incidental or consequential damages.

Under normal use, should the product under warranty fail in material or craftsmanship, DestructData will, at its sole discretion

1. repair and return the product, freight prepaid, and honor the balance of the warranty period, **OR**
2. replace the product, freight prepaid, and honor the balance of the warranty period.

Products that have been damaged through negligence, accident, or misuse of the purchaser or its agents will be, at purchaser's discretion, replaced at purchaser's expense or returned un-repaired, freight collect.

RMA Procedures

Should it be necessary for any reason, to return product to DestructData, an RMA (Returned Material Authorization) number must be obtained and the following procedures must be followed:

1. Fax a request to a DestructData representative, stating the reason for the return.
2. The purchaser will be faxed or emailed an RMA number and instructions for returning products.
3. The RMA number must appear on the shipping label of each carton and all shipping documents that are being returned. The RMA product must be received by DestructData

within thirty (30) days after the authorization date.

4. The Purchaser must ship returned products “prepaid” unless DestructData has agreed in writing to other arrangements.
5. In all circumstances, any products being returned to DestructData must be authorized via DestructData RMA procedures.
6. Items may be returned for replacement or credit only, cash refunds will not be given without specific written authorization, made at the time the RMA is issued by DestructData.
7. Items being returned must be original DestructData products and covered by an applicable warranty period.
8. The authorized returned products must be packaged in their original packing material with all components present. All returned items must be in re-sellable, new, or unused condition. If these requirements are not met, DestructData will recover the loss with increased restocking charges or return the products to the Purchaser.
9. If the Purchaser is requesting a credit to their account, the Purchaser’s written request for the RMA must be made within three (3) days after the receipt of the applicable product(s). Upon acceptance of the returned product(s) by DestructData, the Purchaser’s account will be credited, less a 25% restocking fee. DestructData cannot provide cash refunds.

Important Safety Instructions

1. Read all these instructions.
2. Save these instructions for later use.
3. Following all warnings and instructions marked on the product.
4. Do not use the product near water.
5. This product should be operated from the type of power source indicated on the marking label. If you are not sure of the type of power available, consult your dealer or local power company.
6. Do not attempt to service this product yourself, as opening or removing covers may expose you to dangerous voltage points or other risk. Refer all servicing to authorized personnel.

REMARKS

Guide to Conventions

The following notational conventions will be used throughout this manual. These blocks are warnings or cautions and they are used as follows:



CAUTION

This icon indicates the existence of a potential hazard that could result in personal injury, damage to your equipment, or loss of data if instructions are not observed.



NOTE

This icon indicates important points to consider during the integration process.

Notational Conventions

The following notational conventions will be used in this document.

Dimension will be shown throughout this manual in a U.S. measurement and metric format e.g. 19in. (482.6mm).

Table of Contents

PREFACE	1
LIMITED WARRANTY	1
RMA PROCEDURES	1
IMPORTANT SAFETY INSTRUCTIONS	2
REMARKS	3
<i>Guide to Conventions</i>	3
<i>Notational Conventions</i>	3
CHAPTER 1 - CHASSIS DESCRIPTION	6
OVERVIEW	6
<i>Items Included</i>	6
<i>Items Needed to Be Purchased Separately</i>	6
CHAPTER 2 - FEATURE SUMMARY	7
<i>Chassis Front Panel and Peripheral Bays</i>	8
<i>Chassis Rear I/O Ports and Features</i>	8
<i>Front Panel Controls and Indicators</i>	9
<i>Peripherals</i>	10
<i>Hot Swappable Hard Disk Drives</i>	10
<i>Intrusion Switch</i>	10
CHAPTER 3 - INTEGRATION STEPS	11
BEFORE YOU BEGIN	11
<i>Supplies Needed</i>	11
<i>Understand Assembly Safety Instructions</i>	11
<i>Integration Warnings</i>	12
<i>Removing the Top Cover</i>	13
<i>Changing the Hot Swappable Fan</i>	14
<i>Replacing a Back Panel Kit</i>	15
<i>Fan Power Board</i>	16
<i>Installing the Server Board</i>	19
<i>Removing the Hard Disk Drive Tray</i>	20
<i>Installing a SAS or SATA Hard Disk Drive</i>	20
<i>Setting Up the SCSI ID Parameters on the SCSI SCA Version</i>	21
<i>Installing a Slim Floppy Disk Drive</i>	22
<i>Installing a Slim CD/DVD-ROM Drive</i>	24
<i>Installing the Power Cord</i>	25
CHAPTER 4 - INSTALLING THE SYSTEM INTO A RACK	26
RACK EQUIPMENT PRECAUTIONS	26
INSTALLATION SEQUENCE	27
<i>Fixed Rail Installation</i>	27

Ball Bearing Slide Rail Rack Installation..... 30

CHAPTER 5 – BASIC HARDWARE OPERATION..... 34

Powering on the RED 34

Logging into the RED 34

Attaching the RED to a Network 34

Inserting Drives into the RED 35

Inserting 2.5 inch drives 35

Using Toolless Trays and Tray Inserts..... 37

APPENDIX A - EQUIPMENT LOG 38

APPENDIX B - CALCULATING POWER USAGE..... 39

Chapter 1 Chassis Description

**NOTE**

Some of the pictures/graphics herein are for illustration purposes and could vary from the actual product.

Overview

The DestructData RED240 was designed to support EATX mainboards. Your unit has been configured with a main board meeting your specific configuration. Please see the supplied main board manual for information on this component.

**NOTE**

Electrostatic discharge can damage electronic components. Be sure you are properly grounded before beginning any procedure.

Items Included in your RED240

The following components are included with every RED240

1. 5U rack mount chassis
2. 24 Hard Drive Trays
3. Power Cords (U.S.or European version)
4. One 930W redundant Power Supply
5. One Fan Bracket consisting of three 120mm redundant fans for system cooling
6. One Power Distribution board.

Items Specific to your Configuration

The following components may exist in your RED, please see the included literature for these components:

1. RAID/HBA controller card(s) (Fiber Channel, SCSI, SAS)
2. Server Board (meeting the CPU, Memory and Slot requirement of your order)
3. Minimum of one Intel® Xeon® processor or one AMD®Opteron processor
4. DDR RAM memory DIMMs
5. Hard Disk Drive(s) (HDD)
6. Slim Floppy Disk Drive (FDD)
7. Slim CD-ROM Drive
8. Other PCI or PCIe add-in cards
9. Other peripheral devices (bar code scanner, printer, KVM, etc)

Chapter 2 *Feature Summary*

The DestructData RED240 provides a rugged and reliable housing for erasure solutions. The chassis is designed to support 24 Hot Swappable SAS or Serial ATA Hard Disk Drives (HDD). The chassis can also feature an optional slim line FDD/CD-ROM and one fixed or redundant PFC power supply.

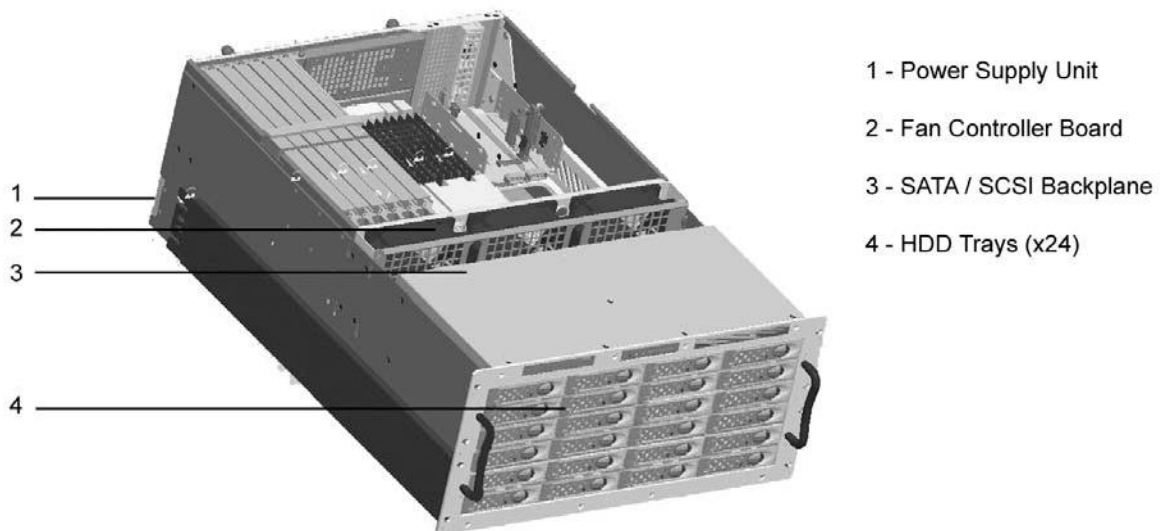

Chassis Front Panel and Peripheral Bays

To access the system controls and peripherals when a front face plate is installed, unscrew the two thumbscrews and gently pull it towards you until it is released from the chassis

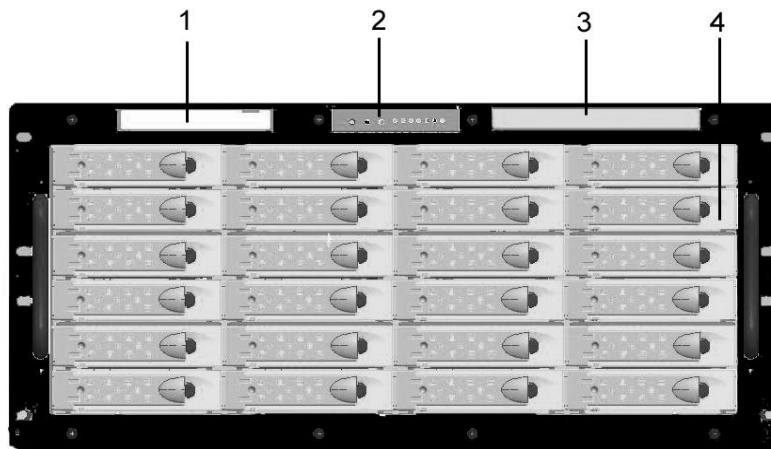

- 1 - Slim Floppy Disk Drive
- 2 - Front Panel Display
- 3 - Slim CD
- 4 - HDD Tray

Chassis Rear I/O Ports and Features

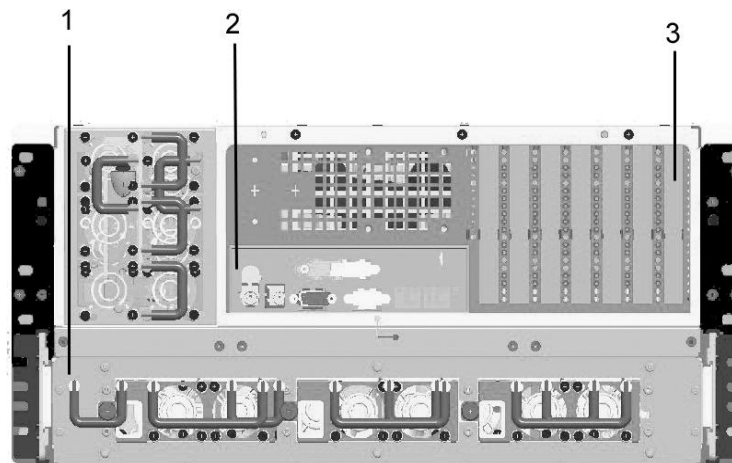

- 1 - Power Supply Unit
- 2 - Serverboard I/O Shield
- 3 - PCI slot brackets

Front Panel Controls and Indicators

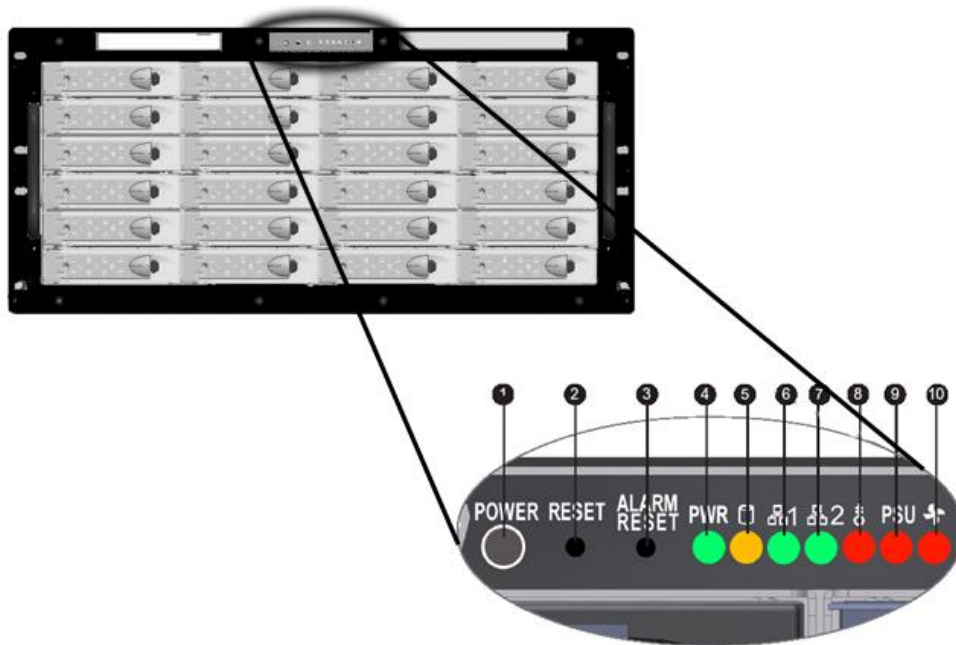

Control Button and functions

1	Power Button	Toggles the system ON/OFF
2	Reset Button	Reboots and initializes the system
3	Alarm Reset Button	Reset the system alarm to mute
4	Power LED	Continuous green light indicates the system has power applied to it Blinking green light indicates the system is sleeping No light indicates the system does not have power applied to it
5	HDD Act LED	Blinking yellow light indicates the hdd is being access
6	NIC 1 LED	Blinking green light indicates the NIC 1 is being access
7	NIC2 LED	Blinking green light indicates the NIC 2 is being access
8	Temperature LED	Continuous amber light indicates the system is too hot
9	Power Fault LED	Continuous amber light indicates the power supply unit failed
10	Fan Fault LED	Continuous amber light indicates the system fan(s) failed

Peripherals

The chassis provides a variety of peripheral options that can be purchased separately and added to the system:

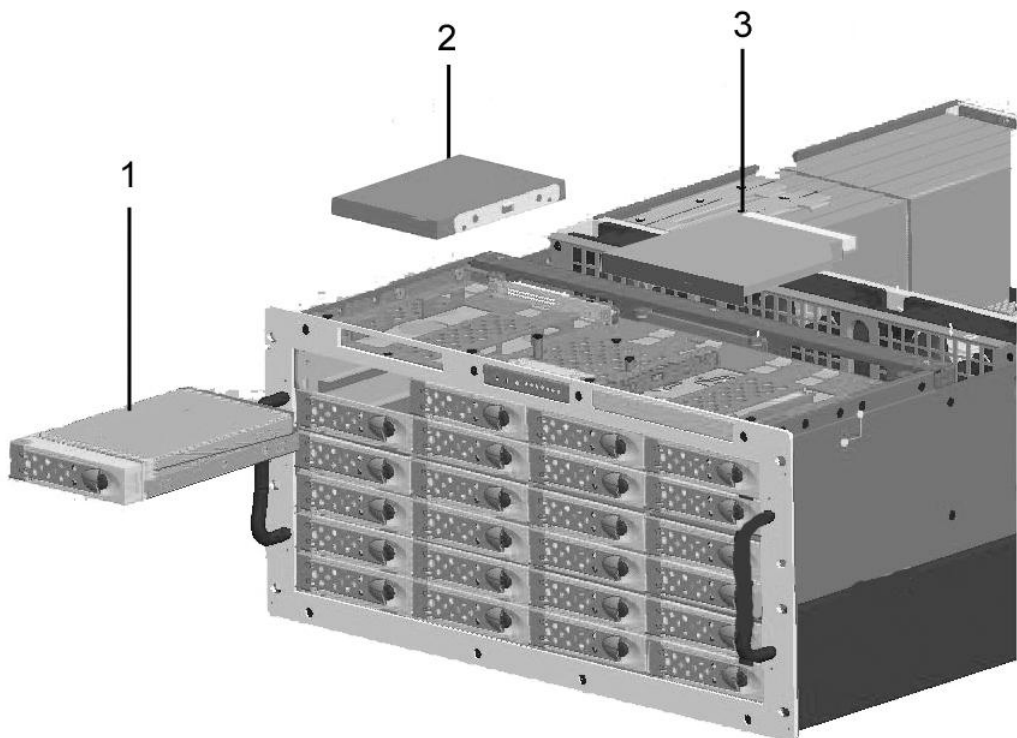

- 1 - Hard Disk Drive 2 - Slim Floppy Disk Drive
3 - Slim CD/DVD-Rom Drive

Hot Swappable Hard Disk Drives

The chassis comes with 24 drive trays for mounting the SAS or SATA hard disk drives. When a drive has completed erasure, the software will detect the completion and display it on screen. (please reference software Manual for software operating specifics) As the drives are hot swappable, a support technician can then replace the completed drive with another drive and continue the erasure process without shutting down the system.

Intrusion Switch

The system **may** include a preinstalled intrusion switch for the access cover that can be monitored by server management software. When the cover is opened, the switch, located on the upper right hand corner of the chassis will transmit a signal to the server board where server management software will process the signal and respond by, for example, powering down the system or locking the keyboard.

Chapter 3 *RED240 Construction Overview*

Before You Begin

Your RED240 was most likely shipped to you fully assembled and ready for final installation at your facility. However, in the event your configuration required the unit to be partially disassembled, or for the purposes of upgrading the unit, the following integration steps help guide you through the basic assembly, integration or upgrade process.

**CAUTION**

System components must be installed in the order presented in the assembly instructions. Component damage may result if installed in a different order.

Supplies Needed

Before beginning, you should make sure you have the following components available:

- Anti-static wrist strap
- Optional peripherals and add-in cards
- Philips screwdriver

Understand Assembly Safety Instructions

Before installation, you should make sure you follow certain basic safety precautions

**CAUTION**

Integration and servicing of this chassis assembly should only be performed by technically qualified persons.

Follow these guidelines to meet and maintain safety and product regulatory requirements when integrating this chassis assembly.

Read and adhere to all of these instructions and the instructions supplied with this assembly. If you do not follow these instructions, the UL listing and other regulatory approvals may become void, and the product will be non-compliant with regional product laws and regulations.

Integration Warnings

These warnings and cautions apply whenever you remove the chassis top cover to access the internal components.



NOTE

Electrostatic discharge can damage electronic components. Be sure you are properly grounded before beginning any procedure.

Safety Guidelines

1. Turn off all peripheral devices connected to the server.
2. Turn off the RED240 from the OS or by pressing the power button on the front of the chassis, then, unplug the AC power cord from the chassis. Disconnect all the peripheral cables and all network cable connected to the chassis.
3. Provide electrostatic discharge protection by wearing an antistatic wrist strap attached to ground.



NOTE

1. *The power button on the front or rear panel DOES NOT turn off the AC power. You MUST unplug the AC power cord.*
2. *Hazardous electrical conditions may be present on power, network, and peripheral cables. Turn off the computer and disconnect all the cables before opening it. Otherwise, personal injury or component damage may result.*



CAUTION

Do NOT open the Power Supply Unit. Hazardous voltages and currents are present within the power supply. Refer servicing of the power supply to a qualified technician.

Removing the Top Cover

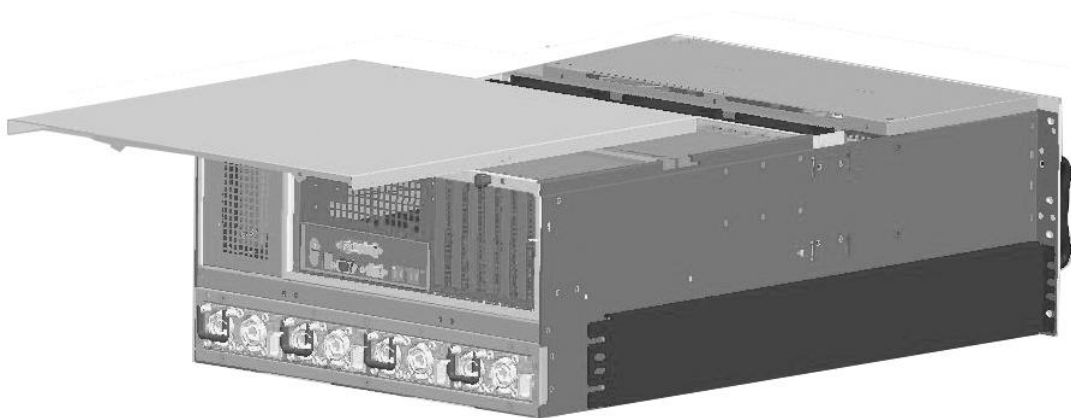

1. Unscrew the thumbscrew by turning in the counter-clock-wise direction on the rear of the chassis. If the thumb screw is too tight, use a Philips screwdriver to loosen it.
2. Pull the top cover handle backward and slide the whole cover back until you can lift it up from the chassis.
3. Set the top cover away from the immediate working area

Changing the Hot Swappable Fan

If a fan has failed, the system alarm will beep and the Fan Fault LED will light up. In addition, the fan board will display a fault LED for the defective fan. Follow these procedures to replace the failed fan.

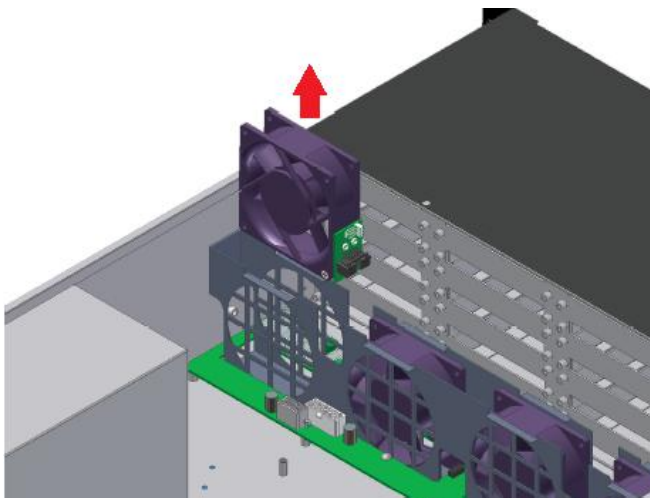

1. Remove the thumb screws from the fan bracket. Pull out the defective fan from the chassis as shown.

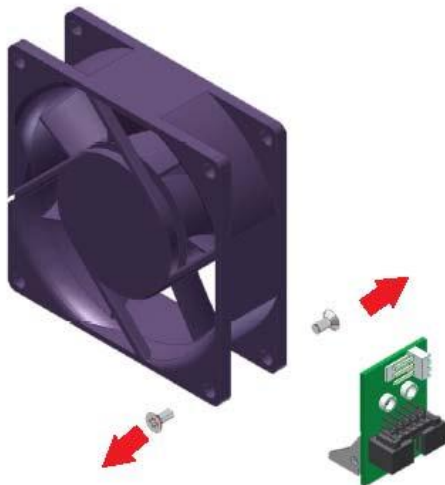

2. Unplug the 3-pin power cable from the fan power adapter board. Remove the two flat head mounting screws as shown. Remove the fan power adapter board.

3. Replace with a functional fan and reverse steps 1 and 2.

Replacing a Back Panel Kit

The back panel (IO panel) for the RED240 comes with a motherboard I/O shield cutout with seven PCI slots.

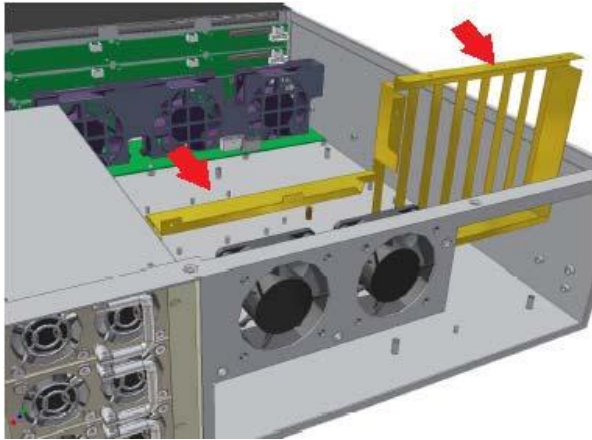

1. Before removing the back panel, remove the server board or other add-in equipment that is mounted to the back panel.
2. Unscrew the eight flat head mounting screws with a Philips screwdriver as shown in the figure.
3. Slide the back panel towards the middle of the chassis until you can lift it up away from the chassis
4. Reverse Steps 1 to 3 to replace the new back panel

Fan Power Board

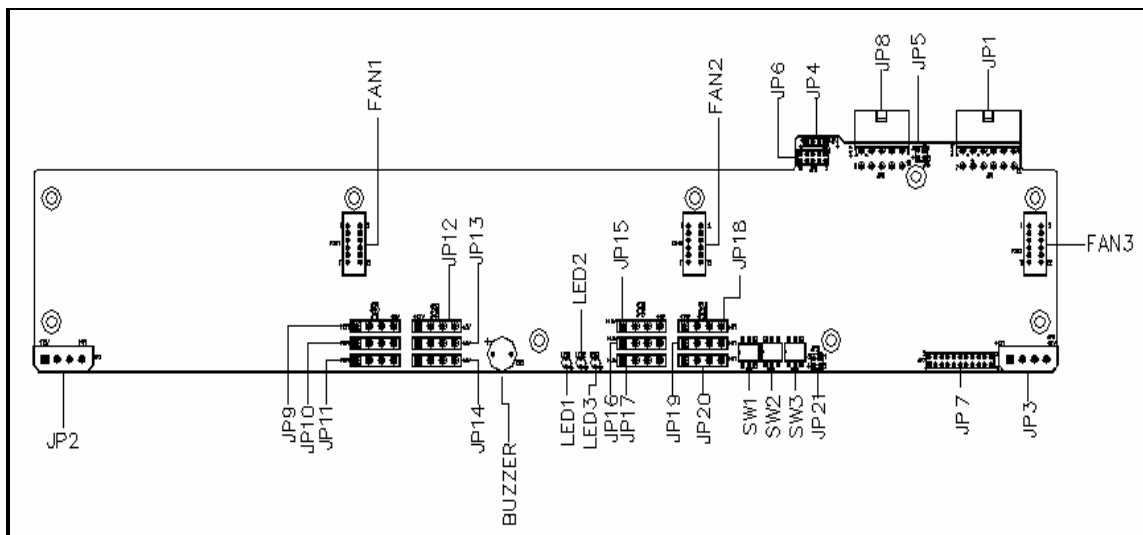

	Function	Setting
JP1	12 volt power connector	Connected to power supply
JP2, JP3	4 pin DC power connector	Power for peripheral devices
JP4	I ² C header	Not used in SR524
JP5	Power input header	See Section 1.1
JP6	Motherboard connector header	See Section 1.2
JP7	Front panel connector header	See Section 1.3
JP8	5 volt power connector	Connected to power supply
JP9 to JP20	4 pin DC power connector	Power for backplanes
JP21	Thermocouple header	See Section 1.4
SW1	Hot swap fan switch	See Section 1.5
SW2, SW3	Thermocouple threshold switch	See Section 1.6 for setting
LED1, LED2, LED3	Fan status LEDs	None
FAN1, FAN2, FAN3	Hot swap fan header	Connected to hot swap fans

*This diagram is representative of the latest board revision available at the time of publishing.

1.1 Power Input Header (JP5)

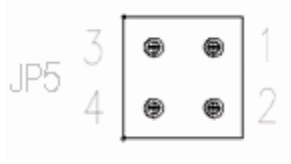

JP5	Power Input Header
1, 2	Power Supply Reset Input
3	Power Fail (TTL)
4	Ground

1.2 Motherboard Connector Header (JP6)

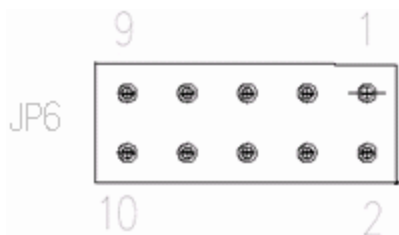

JP6	Motherboard connector header			
1, 2	System Power Switch			
3, 4	System Reset Switch			
5	Access LED+	6	Access LED-	
7	LAN1 LED+	8	LAN1 LED-	
9	LAN2 LED+	10	LAN2 LED-	

1.3 Front Panel Connector Header (JP7)

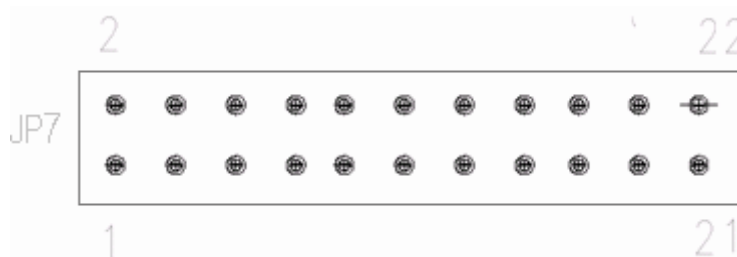

JP7	Front panel connector header			
1, 2	System Power Switch			
3, 4	System Reset Switch			
5, 6	Buzzer Alarm Reset Switch			
7	Power LED+	8	Power LED-	
9	Access LED+	10	Access LED-	
11	LAN1 LED+	12	LAN1 LED-	
13	LAN2 LED+	14	LAN2 LED-	
15	Temperature Green LED	16	Temperature Red LED	
17	Fan Green LED	18	Fan Red LED	
19	Power Fail Green LED	20	Power Fail Red LED	
21, 22	Ground			

1.4 Thermocouple Header (JP21)



JP21	Thermocouple header	
1, 2	Sensor 1	
3, 4	Sensor 2	

1.5 Hot Swap Fan Switch (SW1)

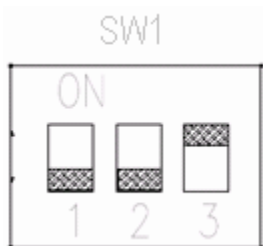

Hot swap fan switch	
Piano Switch Setting	FAN detection control
Number 1 up "ON" 2 and 3 down "OFF"	FAN 1 detect enabled
Number 2 up "ON" 1 and 3 down "OFF"	FAN 2 detect enabled
Number 3 up "ON" 1 and 2 down "OFF"	FAN 3 detect enabled
All down "OFF"	Fan detection disabled

1.6 Thermocouple Threshold Switch (SW2, SW3)

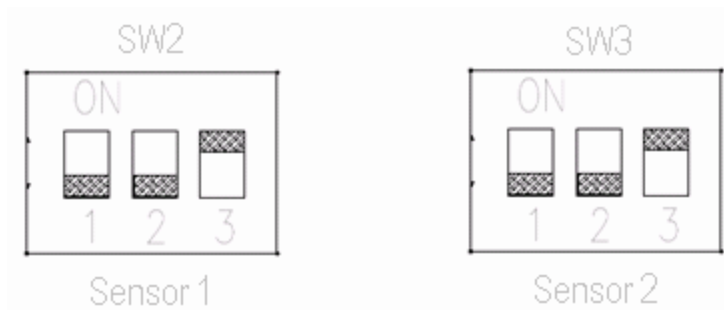

Thermocouple threshold switch	
Piano Switch Setting	Threshold Result
Number 1 up "ON" 2 and 3 down "OFF"	Threshold at 45°C
Number 2 up "ON" 1 and 3 down "OFF"	Threshold at 55°C
Number 3 up "ON" 1 and 2 down "OFF"	Threshold at 65°C
All down "OFF"	Disable Feedback from Thermocouple

Installing the Server Board

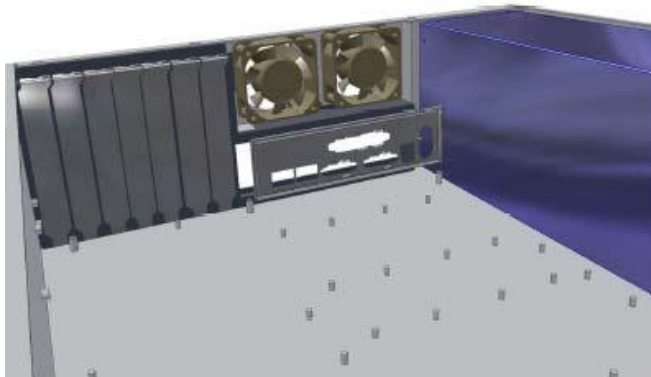

1. Install the I/O shield from the inside of the chassis to the back panel.

Position one edge so the groove is outside the back panel wall and push until it is seated completely.

Make sure the I/O shield's edges snap into place (Refer to your server board manual for further instruction.)

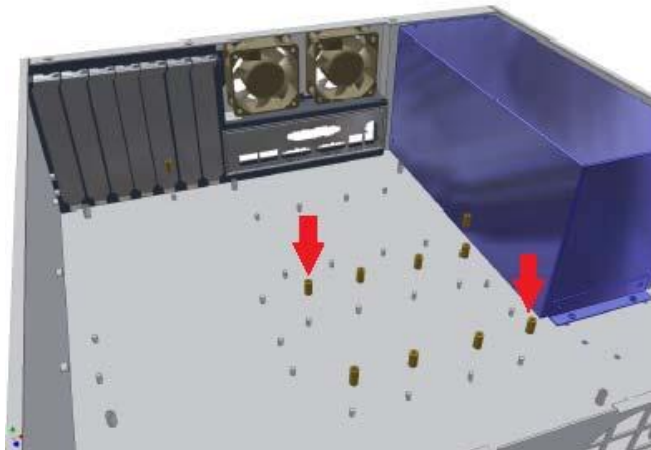

2. Check the server board mounting holes location. Place the brass spacer from the accessories box into the chassis stud according to the server board mounting holes location as shown.

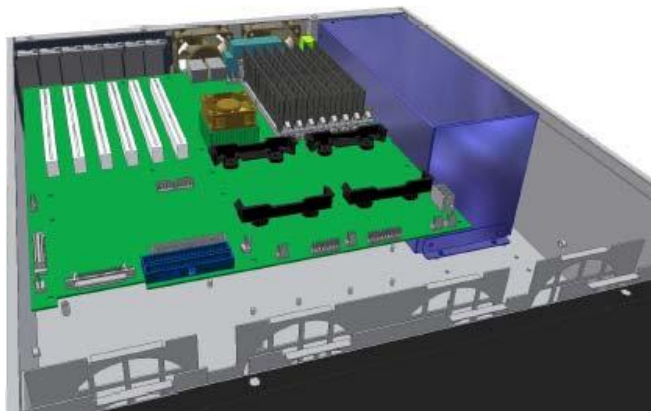

3. With the brass standoffs installed into the correct location, place the server board carefully into the chassis and secure the server board with the provided #6-32 screws.

Removing the Hard Disk Drive Tray

Follow the instructions below to remove the Hard Disk Drive Tray from the chassis:



1. Pull the retention lever toward you, the lever will become free from the housing slot.



2. Pull the hard drive tray until it is free from the chassis.

Installing a SAS or SATA Hard Disk Drive



1. Remove the hard drive from its wrapper, and with the drive circuit-side-down, position the connector end so that it is facing the rear of the carrier. Align the holes in the drive to the holes in the drive mounting tray. Insert the provided screws into the tray and secure the drive.

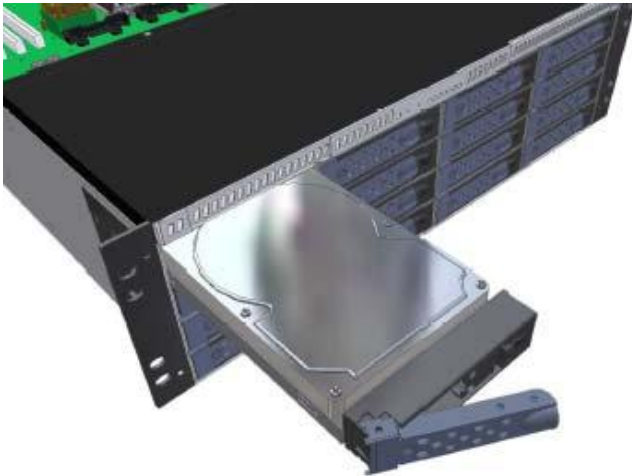

2. Push the drive tray into the drive bay slot.

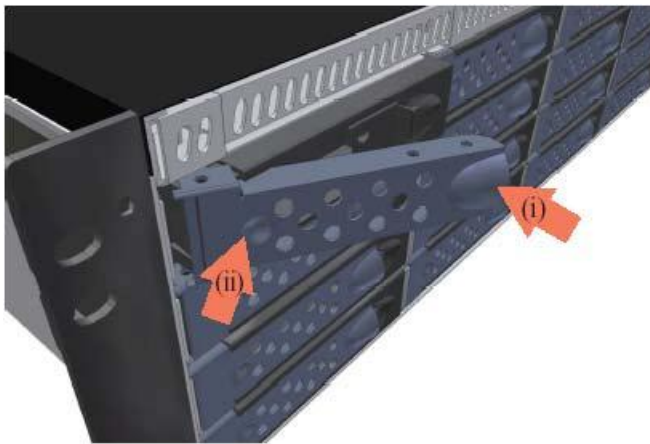

3. Secure the drive into the bay:
(i) Push the right corner of the tray (not the retention lever) with your thumb toward the chassis, The retention lever will automatic shift toward the mounting tray slot.

(ii) Push the retention lever to lock in the drive tray.

Installing a Slim Floppy Disk Drive

The chassis allows the user to install a slim floppy disk drive. Follow these steps:



1. Unscrew the two screws of the front top cover and take the cover apart.

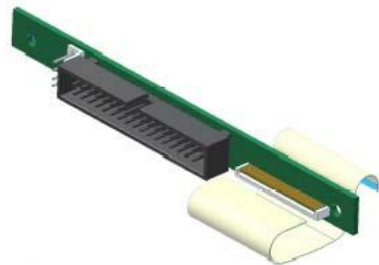

2. Take the slim FDD-drive adapter PCB from the package. (This part may need to be purchased separately) Install the data cable to the board as shown. Make sure the side colored blue is face down on the chassis.



3. Mount the slim FDD-drive adapter PCB into the chassis. Tighten the two screws that come with the slim FDD-drive adapter PCB as shown.

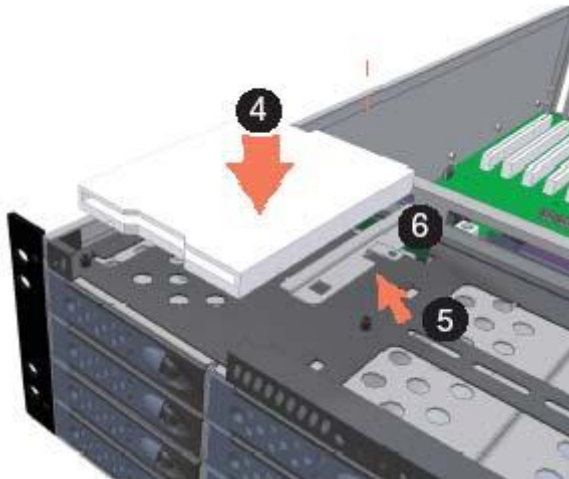

4. Place the slim FDD drive into the chassis. Align the drive mounting holes to the chassis hooks.

5. Slide the mounting hooks towards the slim FDD-drive.

Fasten the mounting screw from the top of the chassis to secure the drive as shown.

6. Connect the data cable, the mini 4-pin power connector, and the 34 pin floppy disk connector to the proper position.

Installing a Slim CD/DVD-ROM Drive



1. Unscrew the two slim CD-ROM cover plate mounting screws.
2. Pull out the slim CD-Rom cover plate and put it back into the accessories box.

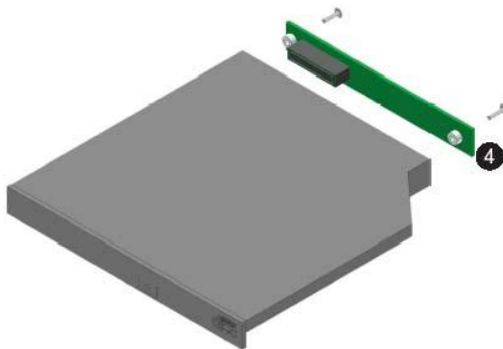

3. Take the slim CD/DVD drive from the package and the slim CD/DVD adapter PCB from the accessories box. (These parts may have to be purchased separately)

4. Mount the slim CD/DVD adapter PCB into the slim CD/DVD drive. Tighten the two screws as shown.

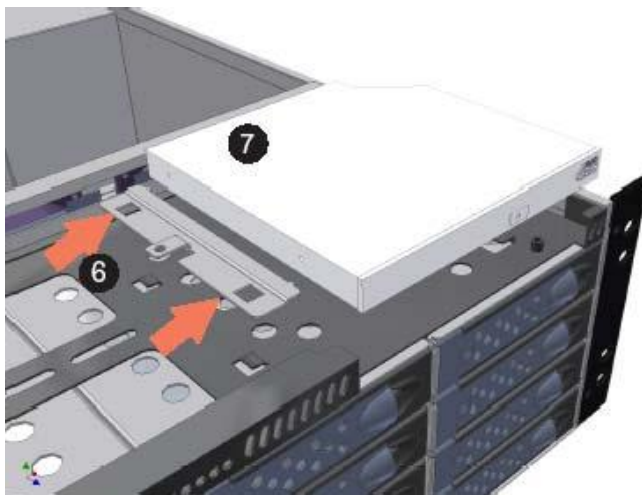

5. Place the CD/DVD-drive into the chassis. Align the CD/DVD drive mounting holes with the chassis hooks.

6. Slide the mounting hook towards the CD/DVD-drive as shown.

7. Fasten the mounting screws from the top of the chassis to secure the drive as shown.

8. Connect the mini 4-pin power connector and the 40-pin IDE connector to the proper position.

Installing the Power Cord



If the power cord supplied with the system is not compatible with the AC wall outlet in your region, get one that meets the following criteria:

- The cord must be rated for the available AC voltage and have a current rating that it at least 125% of the current rating of the server.
- The plug on the power cord that plugs into the wall outlet must be a grounding-type male plug designed for use in your region.
- The connector that plugs into the AC receptacle on the power supply must be an IEC 320, sheet C13, type female connector.
- In Europe, the cord must be less than 4.5 meters long and it must be flexible <HAR> (harmonized) or VDE certified cordage.

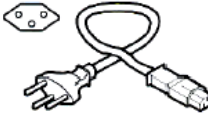
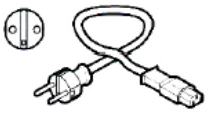
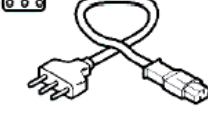
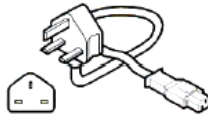

CAUTION

Do not attempt to modify or use the supplied AC power cord if it is not the exact type required.

Country	Cable Type	Country	Cable Type
US		Switzerland	
Continental Europe		Italy	
UK		Australia New Zealand	



NOTE

Please contact your sales representative for order information.

Chapter 4 *Installing the System into a Rack*

The RED240 is a rack mounted chassis. In some cases your RED was already rack mounted in a portable rack when it arrived. If not, please follow these procedures for rack mounting your RED device.

Mounting holes on the front panel are set to RETMA spacing and will fit into any standard equipment rack with appropriate available vertical space.

MODEL	Height in Rack U	Inches Equivalent	MM Equivalent
RED 80	2	3.5	89
RED 160	3	5.25	134
RED 240	5	8.75	223
RED 480	8	14	356

Rack Equipment Precautions

This document should be used only as an information source for planning your deployment. Avoid personal injury and equipment damage by following accepted safety practices.

Floor Loading

CAUTION: Ensure proper floor support and ensure that the floor loading specifications are adhered to. Failure to do so may result in physical injury or damage to the equipment and the facility. Deployment of rack servers, related equipment, and cables exceeds 1800 pounds for a single 42U rack.

External cable weight contributes to overall of the rack installation. Carefully consider cable weight in all designs

Installation Requirement

CAUTION: Be aware of the center of gravity and tipping hazards. Installation should be such that a hazardous stability condition is avoided due to uneven loading. DestructData recommends that the rack footings extend 10 inches from the front and back of any rack equipments 22U or higher. Adequate stabilization measures are required. Ensure that the entire rack assembly is properly secured and that all personnel are trained in proper maintenance and operation procedures. Tipping hazards include personal injury and death.

Power Input and Grounding

CAUTION: Ensure your installation has adequate power supply and branch circuit protection. Check nameplate ratings to assure there is no overloading of supply circuits that could have an effect on over current protection and supply wiring. Reliable earthing of this equipment must be maintained. Particular attention should be given to supply connections when connecting to power strips, rather than direct connections to the branch circuit.

Thermal Dissipation Requirement

CAUTION: Thermal dissipation requirements of this equipment deployment mandate minimum unrestricted airspace of three inches in both the front and the rear. The ambient within the rack may be greater than room ambient. Installation should be such that the amount of air flow required for safe operation is not compromised. The maximum temperature for the equipment in this environment is 122°F (50°C). Consideration should be given to the maximum rated ambient.

Installation Sequence



CAUTION

It is strongly recommended to securely fasten the mounting rack to the floor or wall to eliminate any possibility of tipping of the rack. This is especially important if you decide to install several REDs' in the top of the rack.

A brief overview of server installation follows:

1. Select an appropriate site for the rack.
2. Unpack the RED and rack mounting hardware.
3. Attach the rack mounting hardware to the rack and to the RED.
4. Mount the RED into the rack.
5. Connect the cables.
6. Turn on and initialize the RED.

Fixed Rail Installation

Skip this procedure if side rails are to be used. For fixed installation, mount the two rear brackets with the provided screws as shown in the figure below. The bracket includes multiple holes allowing the enclosure to be mounted in racks of varying depths.



1. Tighten the screws into the rear rack bracket on both sides of the chassis with the screws provided.

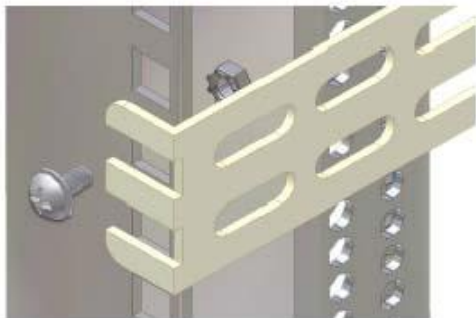

2. While holding the chassis in the mounting position, tighten the screws and the nuts in the rear of the rack cabinet. Some rail-frames have threaded mounting holes; if that is the case, simply tighten the mounting screw.

Reverse Angle View

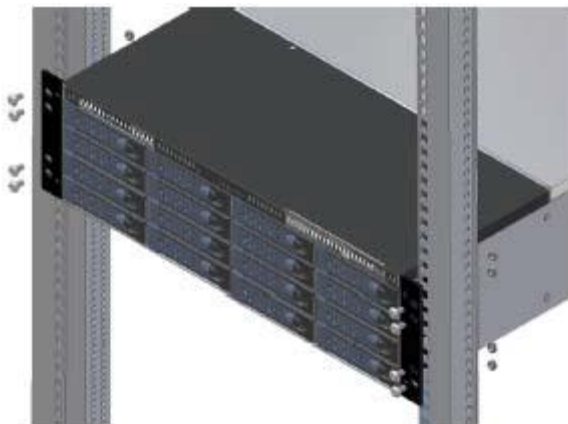

3. Again, while holding the chassis in its mounting position, tighten the screws and nuts in the front side of the rack cabinet or simply tighten the screws in the rack-frames if threaded mounting holes are provided.



4. A view of the final assembly.

Ball Bearing Slide Rail Rack Installation

Unpack the package box and locate the materials and documentation necessary for rack mounting. All the equipment needed to install the server into the rack cabinet is included.

Kit Contents

Contents of the rack mounting kit include:

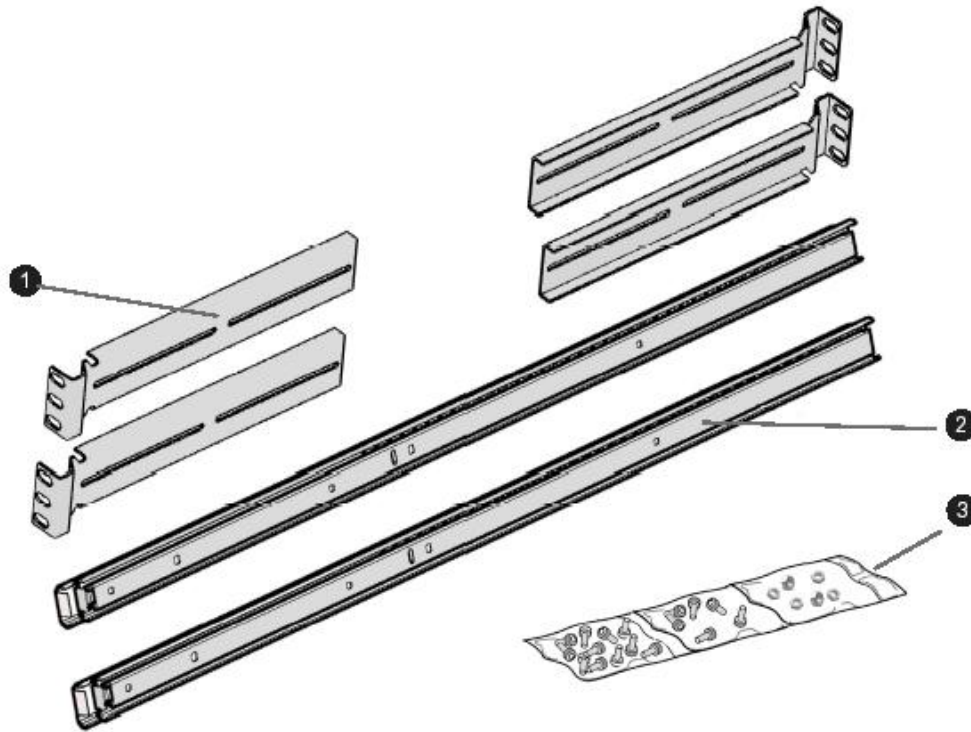

- ❶ Rack mounting brackets (4)
- ❷ Slide rail assembly (2)
- ❸ Bags of screws and nuts (8 x hex nut #8-32, 8 x screw #8-32 1/4 inch, 16x screw #10-32-1/2 inch)

Slide Rail Assembly Components

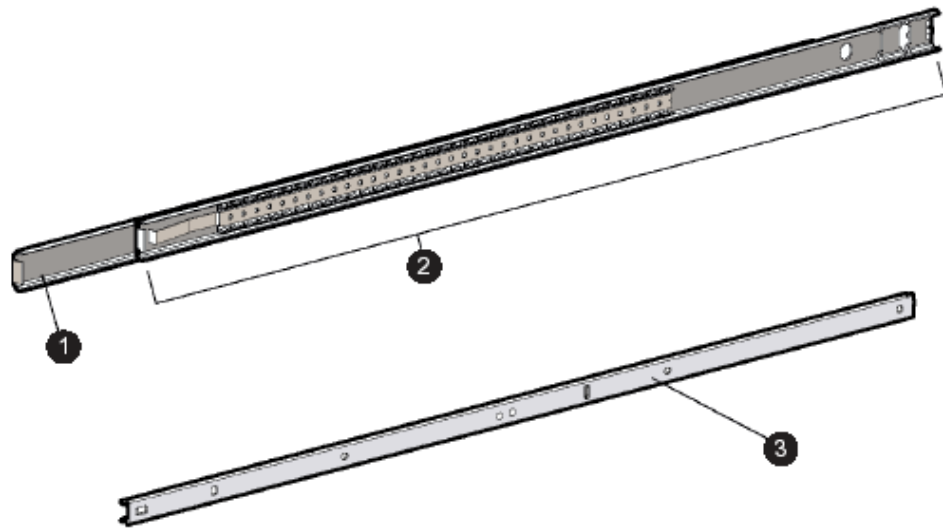

1 Outer Bracket Rail

2 Ball Bearing Inner Slide

3 Server Rail

Remove the Server Rail

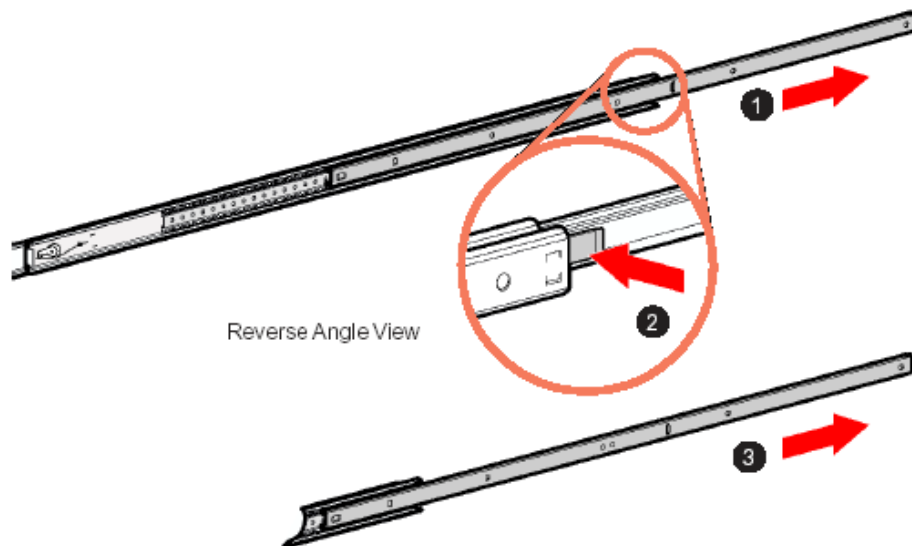

- 1 Extend the server rail from the outer bracket rail until the server rail release latch clicks
- 2 Push down the latch clicks.
- 3 Pull the server rail out of the inner slide

Fasten Bracket and Outer Piece Rail Together

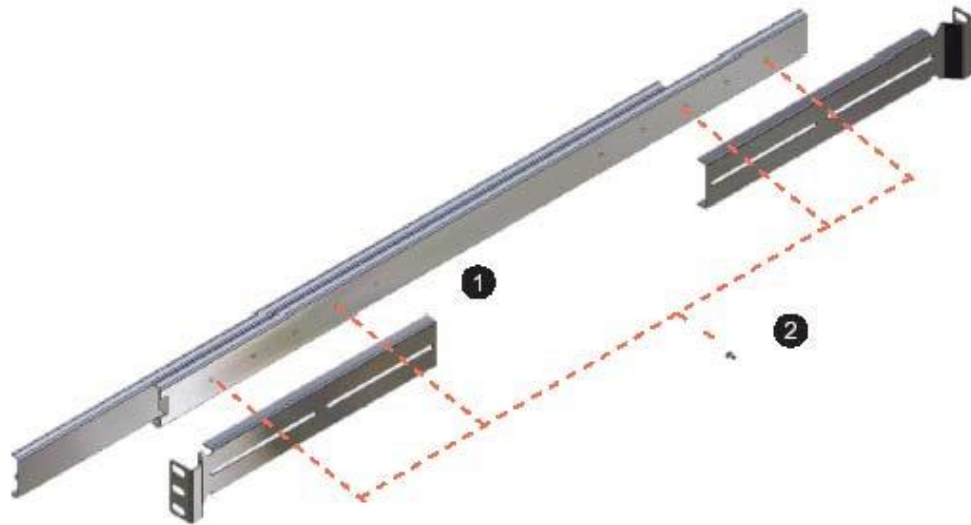

- 1 Align the mounting bracket with the outer rail
- 2 Fasten but not tighten the Bracket with the screws provided

Mount Bracket and Outer Rail to the Rack Cabinet

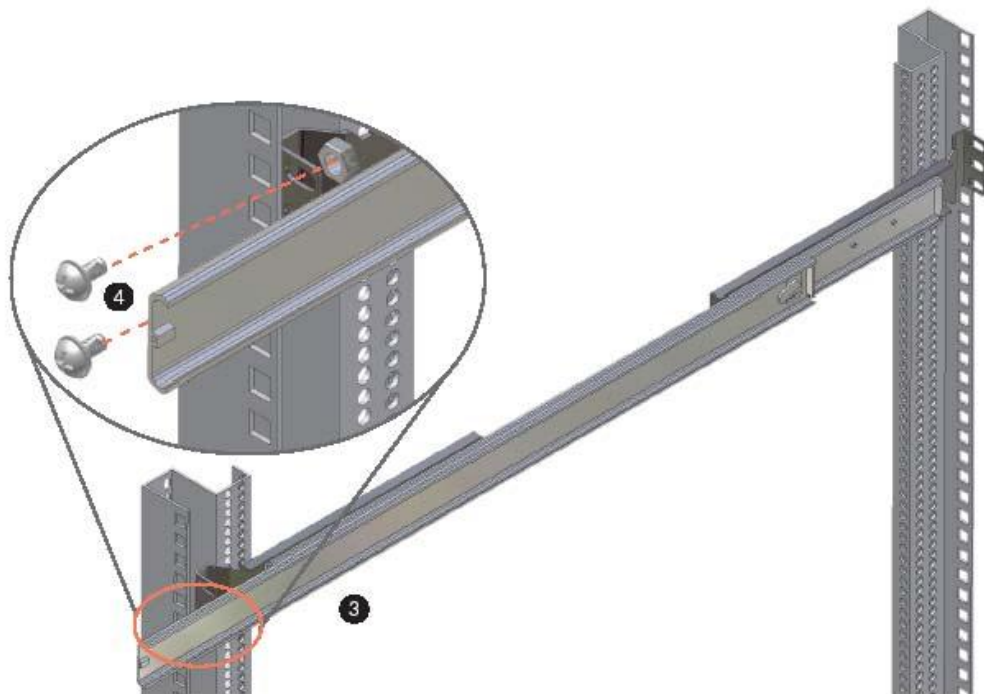

- 3 Align the mounting bracket and the external rail to the rack frame
- 4 Tighten the screw and hex nuts to the rack frame. Then, tighten the screw in step

Assemble Inner Rail to Chassis

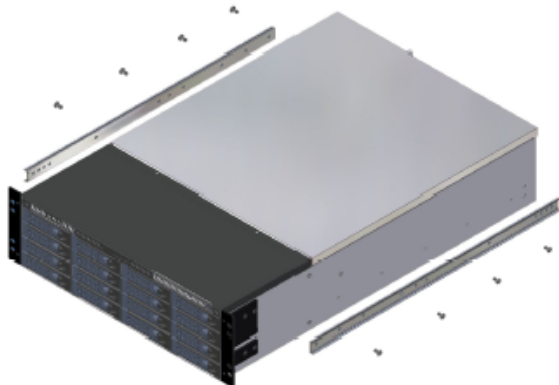

- 1 Place the inner rail along one side of the chassis.
- 2 Align the mounting holes in the inner rail to the mounting holes of the chassis.
- 3 Fasten the inner rail to the chassis using the screws
- 4 Repeat step 1, 2, and 3 to attach the inner rail to the other side of the chassis.



CAUTION

Due to the weight of the chassis with the peripherals installed, lifting the chassis and attaching it to the cabinet may need additional manpower. If needed, use an appropriate lifting device.

Insert Chassis into Rack Cabinet

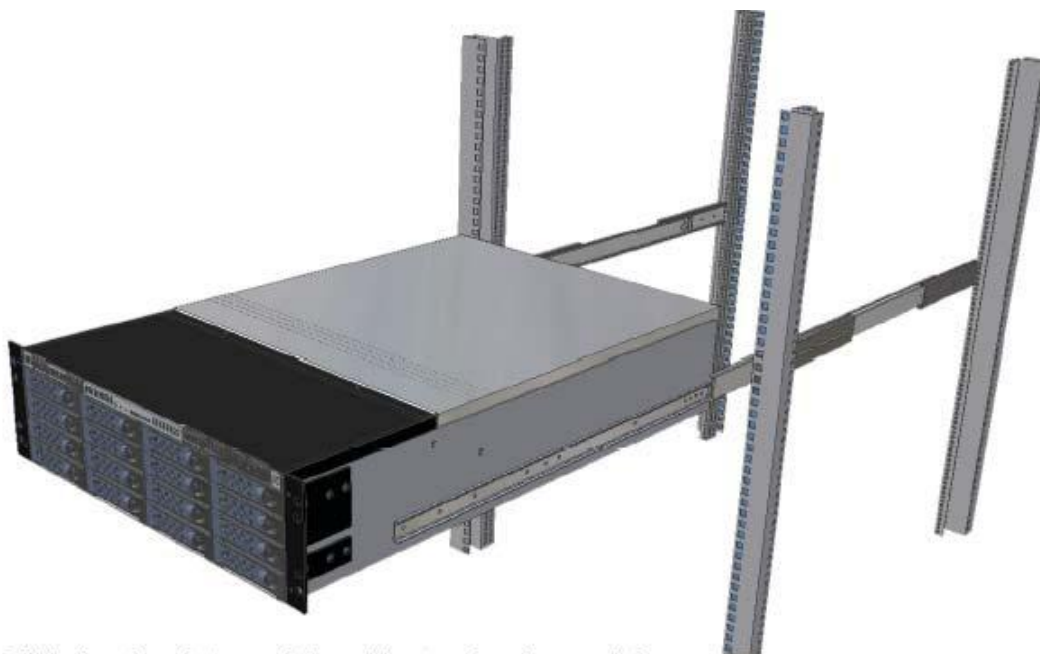

- 1 Slide the chassis toward the cabinet and make sure it is secure.

Chapter 5 *Basic Hardware Operation*

This chapter covers the basic mechanical operation of your RED without consideration for the specific software application that is responsible for performing the actual erasure process. Please see your software manual for information regarding software usage and features.

The RED should be powered OFF whenever the device is not in use. Before powering the device OFF, be sure that all drives have been removed from all the trays of the RED unit, as well as any peripheral units that may be attached to the RED via expansion kits.

Powering ON the RED

**NOTE**

Please be sure that all drives are removed from the RED and any attached expansion peripherals before turning ON power to the RED

Press the front panel POWER button. This will apply power to the RED at which point the fans will be taken to their HIGH speed setting in an effort to remove any dust that may be settled into the unit. The fans will return to their normal operating speed after several minutes.

The unit will go through its normal BIOS boot process, which will include device investigation for each installed drive controller. Leaving hard drives in the RED or attached expansion peripherals can greatly increase the length of time needed for the unit to boot.

Logging into the RED

Your RED runs on Windows 7, when you receive your RED it will not be subject to Windows user account control and will boot immediately to the desktop. If you wish to have user account control enabled, please see your network administrator after reading the section entitled (Attaching the RED to a Network) below.

It is assumed that the erasure software being used requires operator login and will act as a form of application security against accidental or malicious erasure. Please see your software manual for details regarding application specific security features.

Attaching the RED to a Network

The RED should be considered a high security data device. It is recommended that the RED not be attached to any corporate network or Internet connection due to the sensitive nature of the data passing through the unit. The only exception to this recommendation being the installation of an application update which does require a temporary Internet connection be established.

If it is determined that your specific installation requires network connectivity, in order to establish user account control, or to publish erasure application logs to another network location, this can be accommodated using the provided NICs on the rear of the unit. No wireless option exists for the RED at this time.

Inserting Drives into the RED

The mechanical requirements and operation of the drive trays are the same regardless of the erasure application being used.



NOTE

*Please remember that drives **MUST** be stripped of any converters, adapters, trays, sleds, and or mounting hardware before being inserted into the RED.*

If you RED is equipped with standard trays, follow these instructions

Removing the Hard Disk Drive Tray

Follow the instructions below to remove the Hard Disk Drive Tray from the chassis:



1. Pull the retention lever toward you, the lever will become free from the housing slot.



2. Pull the hard drive tray until it is free from the chassis.

Installing a SAS or SATA Hard Disk Drive



1. Remove the hard drive from its wrapper, and with the drive circuit-side-down, position the connector end so that it is facing the rear of the carrier. Align the holes in the drive to the holes in the drive mounting tray. Insert the provided screws into the tray and secure the drive.

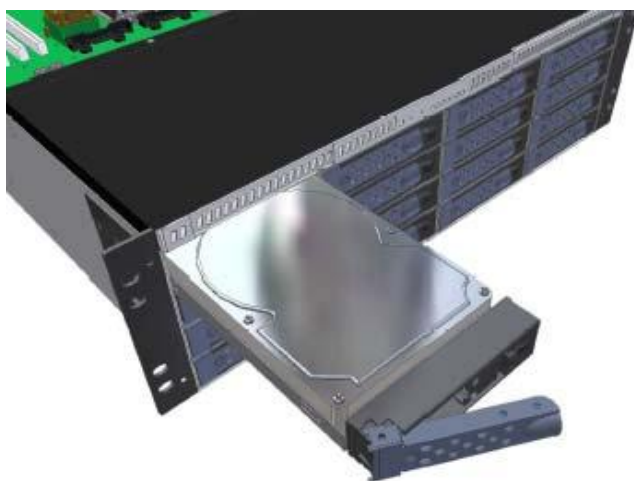

2. Push the drive tray into the drive bay slot.

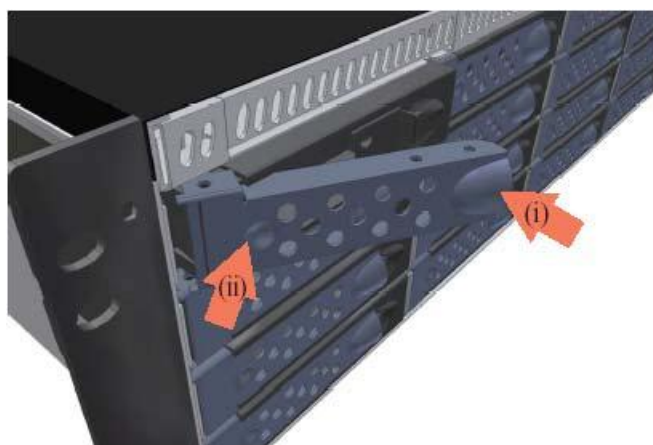

3. Secure the drive into the bay:
(i) Push the right corner of the tray (not the retention lever) with your thumb toward the chassis, The retention lever will automatic shift toward the mounting tray slot.

(ii) Push the retention lever to lock in the drive tray.

Inserting 2.5 Drives

2.5 inch SAS and SATA drives can be mounted into the 3.5 tray. To do this, be sure to align the 2.5 inch drive to the lower right corner of the tray and then use only two of the mounting screws to secure the drive. This will align the drive connector to the back plane and secure the drive sufficiently for the erasure process.

Using Toolless Trays and Tray Inserts

If your RED has been equipped with the Toolless Tray Upgrade, the procedure is identical to that shown above with the exception that you do not need to secure the hard drive with screws. Toolless trays are designed to allow the drive to be inserted and removed without the need for mounting screws, reducing the amount of time needed to process a drive.

To insert a 2.5 inch drive into a toolless tray you must first insert the foam adapter, provided as part of the Toolless Tray upgrade kit. This foam adapter will align the drive correctly and secure it during the erasure process.

Appendix A *Equipment Log*

Use the following worksheet provided below to record information about your system.

Item	Manufacture Name and Model Number	Serial Number	Date Installed
Chassis			
Server Board			
Processor 1			
Processor 2			
Memory			
Video Card			
Hard Disk 1			
Hard Disk 2			
Hard Disk 3			
Hard Disk 4			
Hard Disk 5			
Hard Disk 6			
Hard Disk 7			
Hard Disk 8			
Hard Disk 9			
Hard Disk 10			
Hard Disk 11			
Hard Disk 12			
Hard Disk 13			
Hard Disk 14			
Hard Disk 15			
Hard Disk 16			
Hard Disk 17			
Hard Disk 18			
Hard Disk 19			
Hard Disk 20			
Hard Disk 21			
Hard Disk 22			
Hard Disk 23			
Hard Disk 24			
Slim CD-ROM			
Slim FDD			

Appendix B *Calculating Power Usage*

Calculating DC Current Usage

List all current consumption into the appropriate voltage level for each device and calculate the total current on each voltage level.

Device	Current (Maximum) at voltage level:					
	(+5Vsb)	(+3.3V)	(+5V)	(+12V)	(-5V)	(-12V)
Server Board						
Processor(s)						
Total Memory						
Front Panel LEDs			0.10			
SCSI/ATA/FC backplane			1.00			
Slim Floppy Disk Drive						
Slim CD-Rom Drive						
Total Hard Disk Drives						
Add-in-Card 1						
Add-in-Card 2						
Add-in-Card 3						
Cooling Fans* , 3x120mm				3.00		
Total Current						
Maximum Ratings** (for comparison)	2.0A	44A	44A	50A	1.2A	1.2A

* Typical 7500rpm 40mm x40mm fan. Higher speed fans required more current, refer to the fan label for power consumption information.

** Typical 930W Power Supply, refer to the PSU label for power output characteristics information.

Calculating Total Power Usage

From the worksheet above, enter the total current for each column and then multiply the voltage by the total current to get the total wattage for each voltage level. Add all the wattages up and find the total power usage.

Voltage level and total current	Total Watts for each voltage level
+5 Vsb x ()A =	
(+ 3.3V) x ()A =	
(+ 5 V) x ()A =	
(+ 12 V) x ()A =	
(-5 V) x ()A =	
(-12VV) x ()A =	
Total Combined Wattage	

Disclaimer

Information in this document is provided in connection with DestructData products. No license, express or implied, by estoppel or otherwise, to any intellectual property rights is granted by this document. In no event will DestructData be liable to the purchaser, or to any user of the DestructData product, for any damages, expenses, lost revenues, lost savings, lost profits, or any other incidental or consequential damages arising from the purchase, use or inability to use the DestructData product, even if DestructData has been advised of the possibility of such damages.

DestructData may make changes to specifications and product descriptions at any time, without notice.

Intel and Intel Pentium are registered trademarks of Intel Corporation, other trademarks or trade names mentioned herein are hereby acknowledged as being the property of their respective companies.

Copyright © 2011, DestructData Inc. All Rights Reserved.